

# Daphne Crib Combo Unit

Model No.: 661 / 662  
Po#  
Serial#:



## **WARNING:** READ ALL WARNING & SAFETY INSTRUCTIONS BEFORE ASSEMBLING CRIB. KEEP INSTRUCTIONS FOR FUTURE USE.



First remove hardware from box and sort by size. Check to see that all hardware and wooden pieces are present before assembling. Follow instructions listed below in the proper sequence as numbered to assure fast, easy and correct assembly.

## **WARNING!**



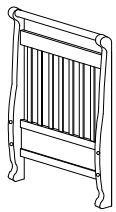
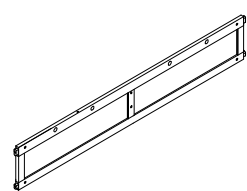
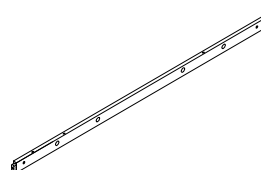
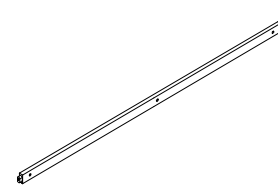
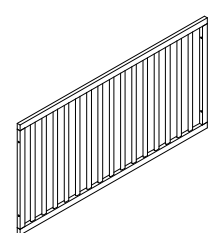
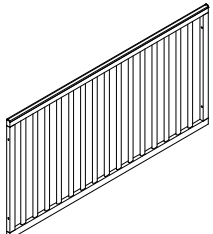
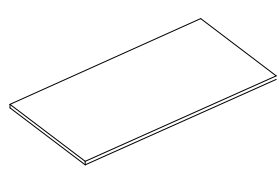

1. DO NOT attempt to repair or modify parts with cracks or defects. Please contact us for immediate replacement.
2. This product is for home use and is not intended for use in schools, day care centers or other commercial establishments.
3. Must be assembled by a capable adult.
4. **CHOKING HAZARDS:** DO NOT put small/loose components on top of the changing table unit where baby could reach.

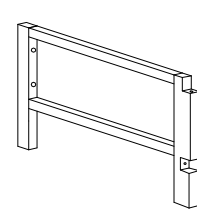
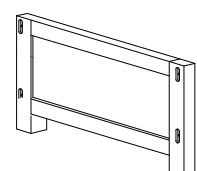
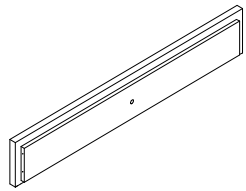
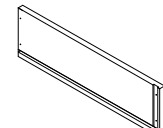
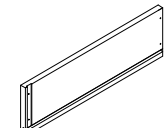
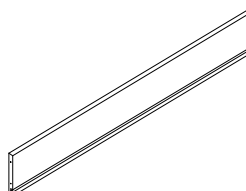
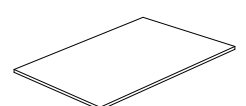
Assembly time approx. 90 mins.

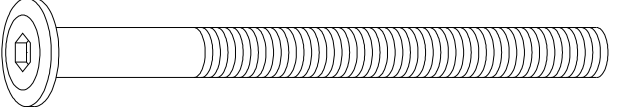
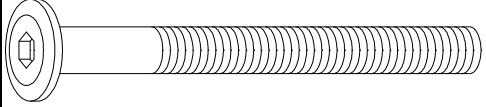
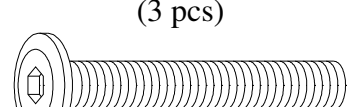
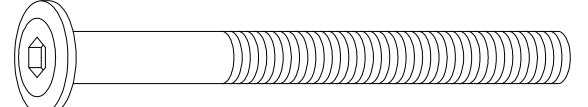

◆ **PARTS IDENTIFICATION (Do not assemble crib if parts are defective. Please contact AFG for exchange or keep the original box for return authorization.)**

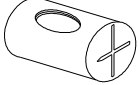
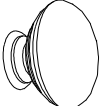
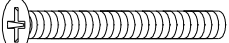
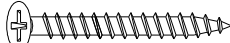
<p>A. Head Board (1 pc)</p> 	<p>B. Fixed Side Bottom Panel (1 pc)</p> 	<p>C. Front Top Rail (1 pc)</p> 	<p>D. Front Bottom Rail (1 pc)</p> 	<p>E. Back Panel (1 pc)</p> 
<p>F. Front Panel (1 pc)</p> 	<p>G. Mattress Support (1 pc)</p> 	<p>H. Mattress Crossbar (4 pcs)</p> 	<p>I. Middle Side Panel (1 pc)</p> 	<p>J. Foot Board Bottom (1 pc)</p> 
<p>K. Drawer Front (2 pcs)</p> 	<p>L. Drawer Left Side (2 pcs)</p> 	<p>M. Drawer Right Side (2 pcs)</p> 	<p>N. Drawer Back (2 pcs)</p> 	<p>O. Drawer Bottom (2 pcs)</p> 

◆ **HARDWARE**

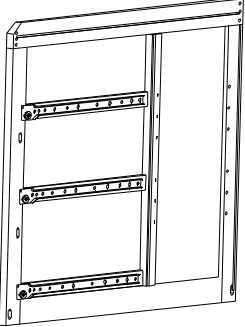
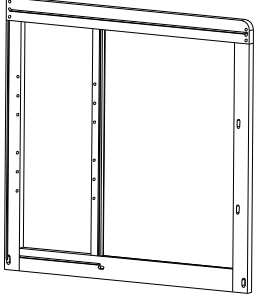
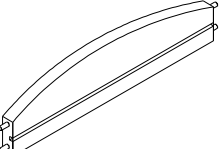
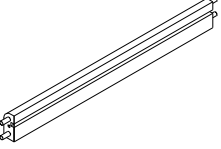
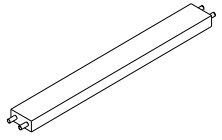
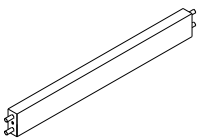
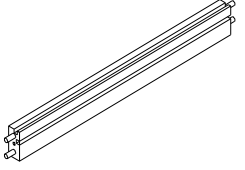
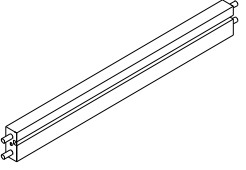
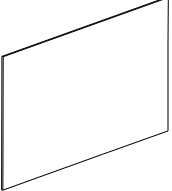
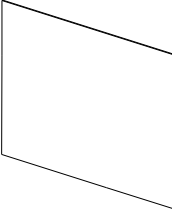
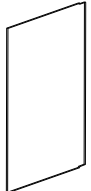
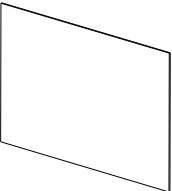

<p>1. Bolt 1/4" x 3" (6 pcs)</p> 	<p>2. Bolt 1/4" x 2-3/8" (4 pcs)</p> 	<p>3. Bolt 1/4" x 1-5/8" (3 pcs)</p> 	
<p>4. Bolt 1/4" x 2-5/8" (8 pcs)</p> 	<p>5. Position Dowel 5/16" x 1-3/16" (6 pcs)</p> 	<p>6. Nut 1/4" x 10 mm (8 pcs)</p> 	
<p>7. Handle (2 pcs)</p> 	<p>8. Bolt 3/16" x 1-1/4" (2 pcs)</p> 	<p>9. Screw 1/8" x 1" (16 pcs)</p> 	<p>10. Wrench (1 pc)</p> 

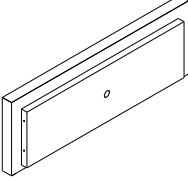
**CHANGING TABLE UNIT PARTS IDENTIFICATION**

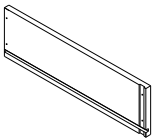
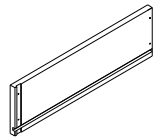
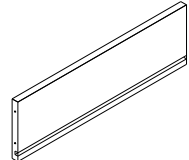
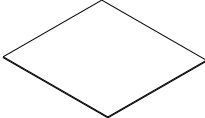
<p>A1. Left Panel (1 pc)</p> 		<p>A2. Right Panel (1 pc)</p> 	
<p>A3. Top Back Panel (1 pc)</p> 	<p>A4. Top Support Bar (1 pc)</p> 	<p>A5. Middle Support Bar (2 pcs)</p> 	<p>A6. Front Bottom Support Bar (1 pc)</p> 
<p>A7. Middle Bottom Support Bar (1 pc)</p> 	<p>A8. Back Bottom Support Bar (1 pc)</p> 	<p>A9. Dresser Top (1 pc)</p> 	<p>A10. Dresser Back Panel (1 pc)</p> 
<p>A11. Shelf Bottom (1 pc)</p> 	<p>A12. Dresser Middle (1 pc)</p> 	<p>A13. Shelf (2 pcs)</p> 	<p>A14. Drawer Front (3 pcs)</p> 

<p>A15. Drawer Left (3 pcs)</p> 	<p>A16. Drawer Right (3 pcs)</p> 	<p>A17. Drawer Back (3 pcs)</p> 	<p>A18. Drawer Bottom (3 pcs)</p> 
---	--	--	---

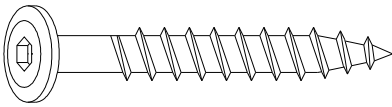
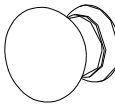
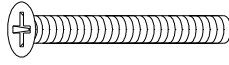
**CHANGING TABLE UNIT HARDWARE**

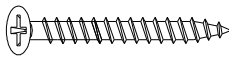
<p>S1. Screw 1/4" x 2" (10 pcs)</p> 	<p>S2. Handle (3 pcs)</p> 	<p>S3. Bolt 3/16" x 1-1/4" (3 pcs)</p> 	<p>S4. Shelf Support Bracket (8 pcs)</p> 	<p>S5. Screw 1/8" x 1" (24 pcs)</p> 
--	---	--	--	---